



Highland TOUGHTANK Oil Storage Tanks

Get a Handle on a Great Value



Engineered to be Tough!

Highland's TOUGHTANK is engineered to withstand unexpected internal pressures. The TOUGHTANK is manufactured to minimize the chance of rupture due to improper filling techniques, faulty equipment, or a clogged vent.

In tests and actual use, Highland's TOUGHTANK withstood internal pressures more than 20 times greater than normal operating conditions.*

Highland 12 gauge TOUGHTANKS are available in 137, 275 and 330 gallon capacities and are UL-80 labeled for fuel oil use. A UL-142 label is available on request. For added security, the 275 and 330 gallon TOUGHTANKS are also available in double-wall construction.

Patented Design

Highland's TOUGHTANK features a uniquely designed head, stamped to form a U-shaped ridge around the tank's perimeter. When assembled, the U-shaped flange fits tightly against the interior tank wall to form a lap joint. A fillet weld then secures the head into position.

Significantly stronger by design, this new configuration also serves to protect the weld from external damage during transportation and installation.

TOUGHTANK

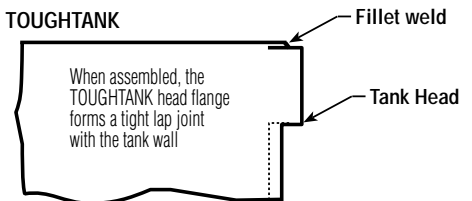

Old Style Basement Tank

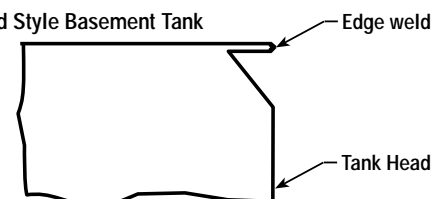

* Warning: Operation of a TOUGHTANK in excess of normal operating pressure (2.5 psi) may cause permanent distortion.

General Arrangement

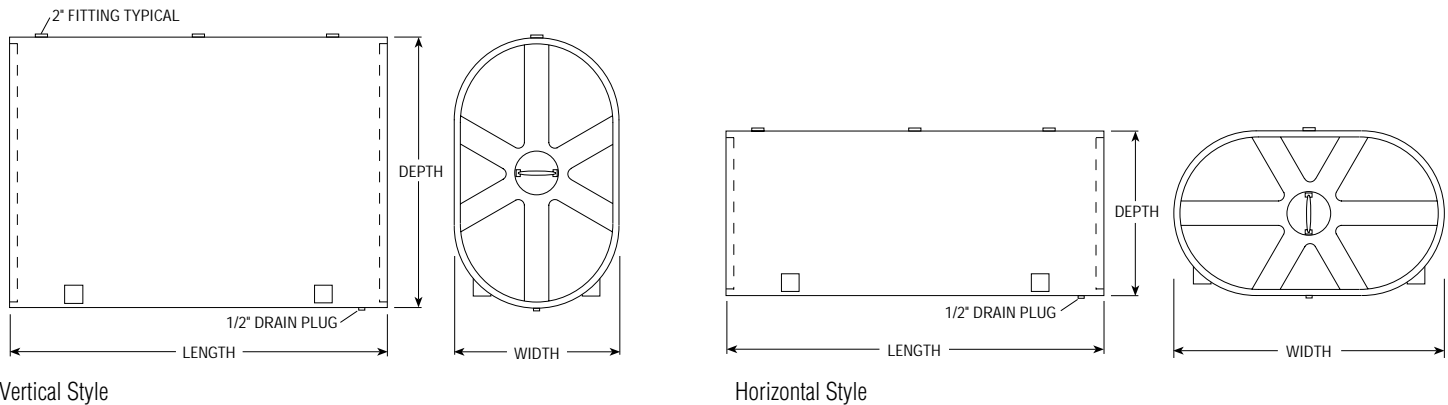

Vertical Tanks

Tank Capacity (Gallons)	Width	Dimensions		Approximate Weight (lbs.)
		Depth	Length	
137	27"	44.25"	32"	170
275	27"	44.25"	62"	279
330	27"	44.25"	74"	320
DW275	27"	44.25"	66"	560
DW330	27"	44.25"	80"	640

Horizontal Tanks

Tank Capacity (Gallons)	Width	Dimensions		Approximate Weight (lbs.)
		Depth	Length	
137	44.25"	27"	32"	170
275	44.25"	27"	62"	279
330	44.25"	27"	74"	320
DW275	44.25"	27"	66"	560
DW330	44.25"	27"	80"	640

UL Approved for Indoor or Outdoor Use

Highland's 12 Gauge TOUGHTANK oil storage tanks bear a UL 80 Label for indoor or outdoor use in accordance with NFPA 31 which permits a UL 142 Label upon request. TOUGHTANKS are designed and fabricated for storage of heating oil. They are painted with primer and are available in finish colors upon request.

Standard Features

- 12 Gauge All-Steel Construction
- Convenient Handle on each Head
- Protective Primed Finish
- UL Labeled

Our Commitment to Industry

Highland's TOUGHTANK is one of many innovative products introduced by our staff in the more than 50 years we've been manufacturing in the U.S.A. For information on any of our other products, please call one of the offices listed below or your local plumbing and heating wholesaler.

Please visit us at www.highlandtank.com



One Highland Road
Stoystown, PA 15563
973-696-1300
FAX 814-893-6126

99 West Elizabethtown Road
Manheim, PA 17545
717-664-0600
FAX 664-0617

958 19th Street
Watervliet, NY 12189
518-273-0801
FAX 273-1365

2700 Patterson Street
Greensboro, NC 27407
336-218-0801
FAX 218-1292

2225 Chestnut Street
Lebanon, PA 17042
717-664-0602
FAX 664-0631

354 Route 108
Somersworth, NH 03878
603-692-2012
FAX 692-2014